

980559

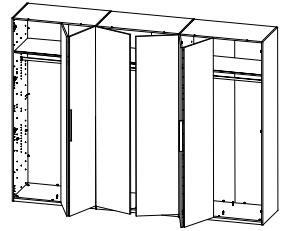

HSP FT 300

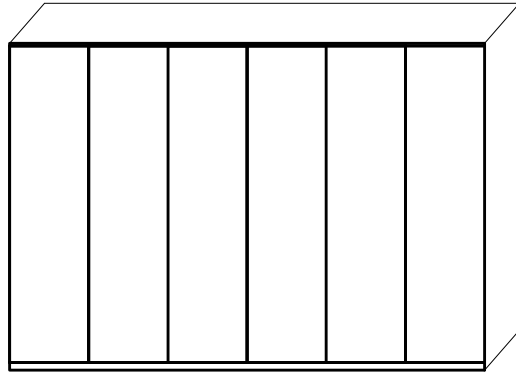
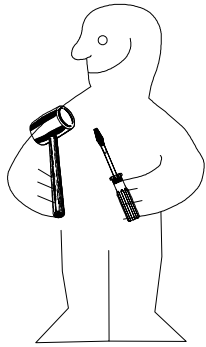
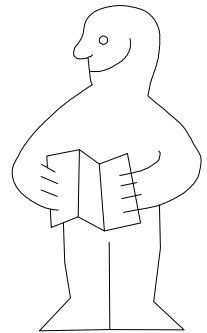
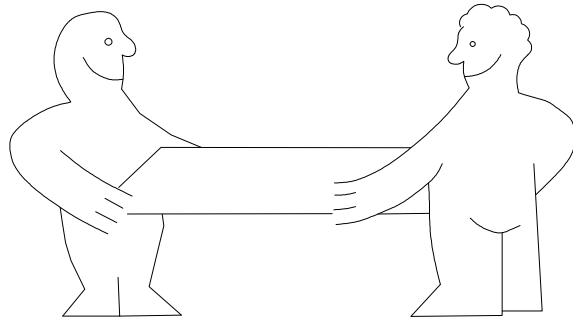
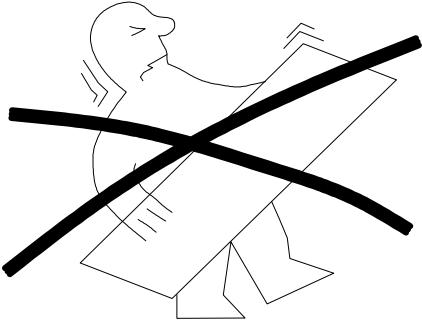

1-2-3-4... ○

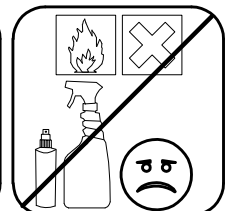
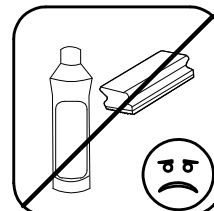
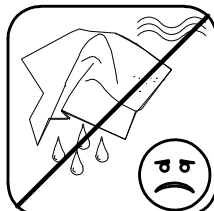
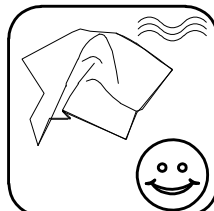
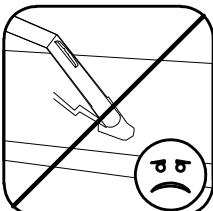
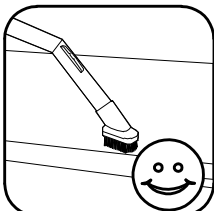
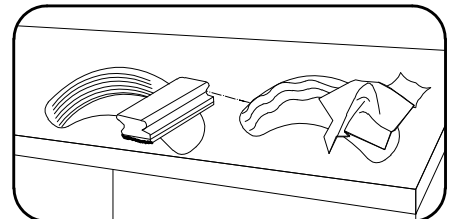
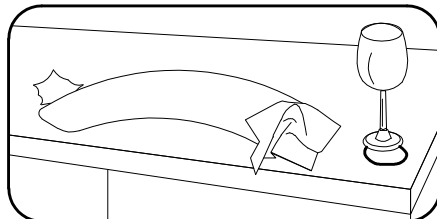
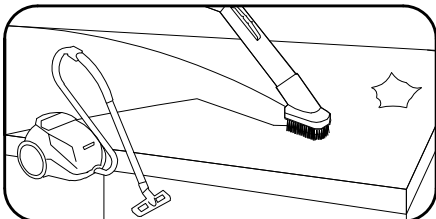
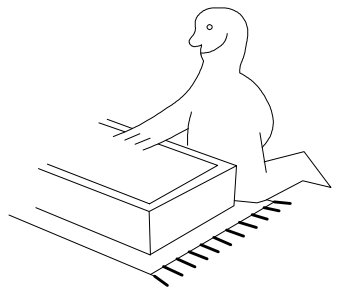
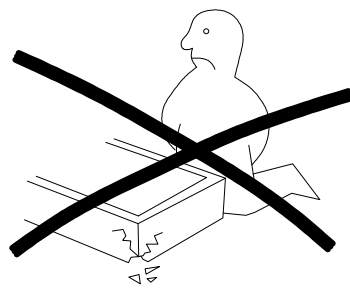
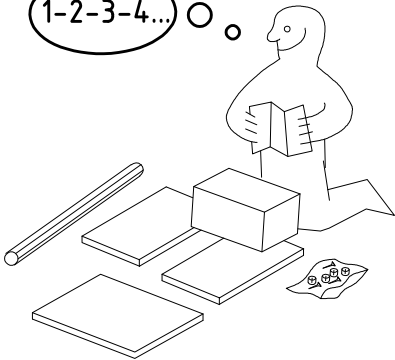

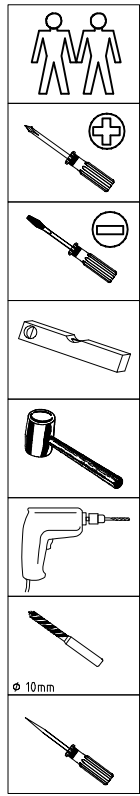

	A1	24x
	C	8x
	F3	8x
	G1	85x
	M1	12x
	N1	12x

	N-D	2x
	S0	15x
	V12	15x
	FPS	4x
	K2	6x
	SBV	24x

	K10	3x
	FS-A	2x
	FP-C	2x
	FTS 1	8x
	FTS 2	8x
	T13	32x

	LRO-L	1x
	LRO-R	1x
	FRO-R	1x
	FRO-L	1x
	J2	9x
	T1	30x

	L8	12x
	KP8	4x
	ø10	1x
	SP13	4x
	AW	4x

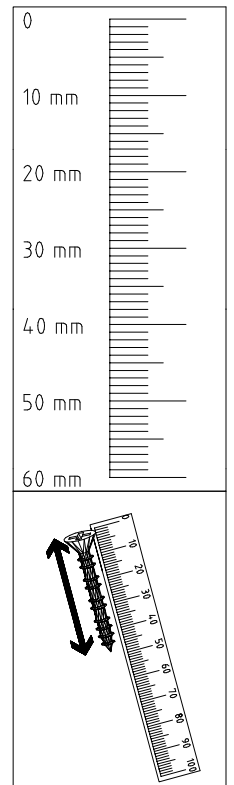
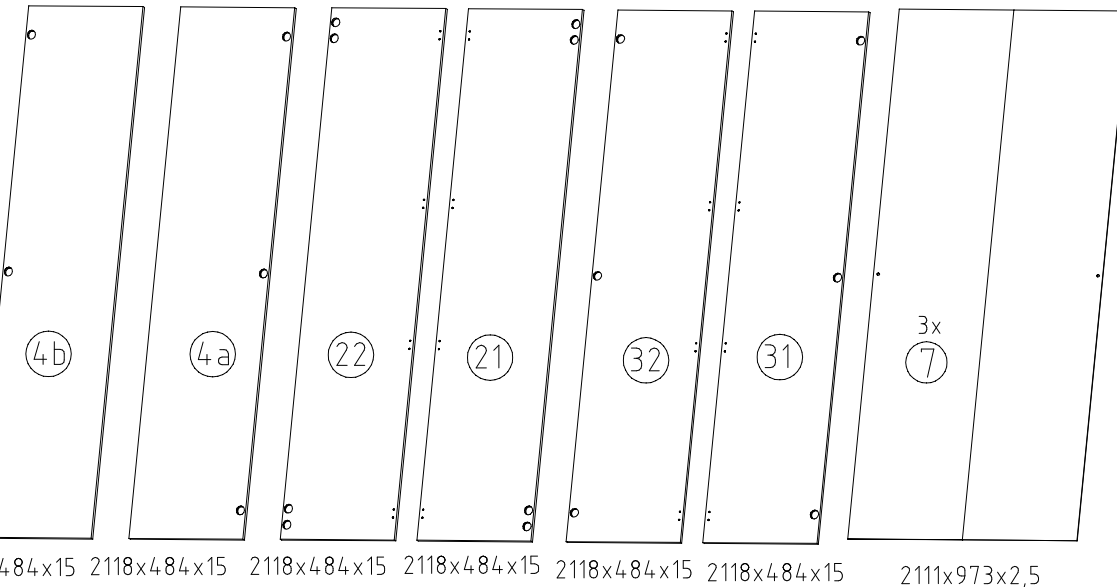
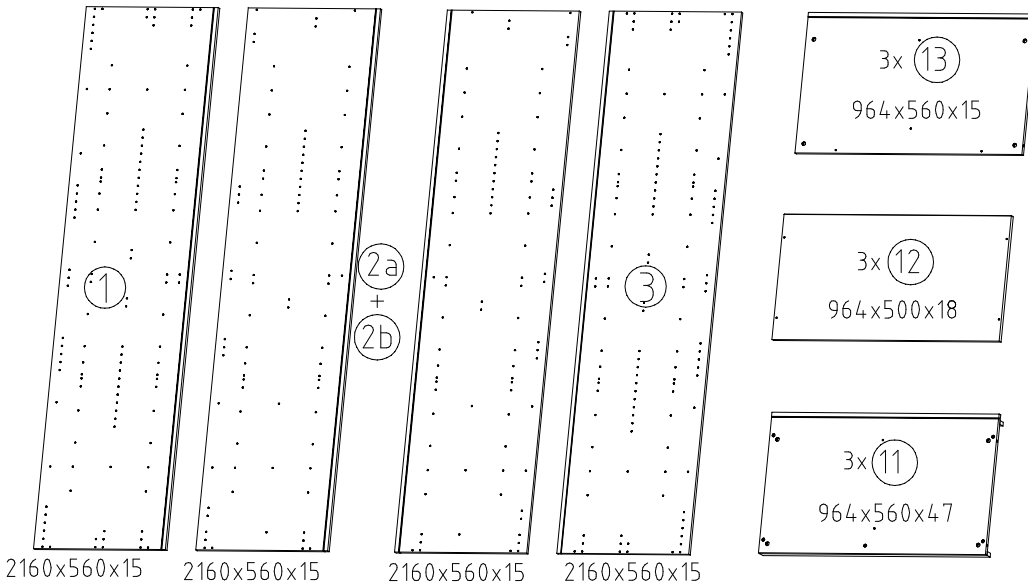

1

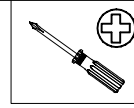
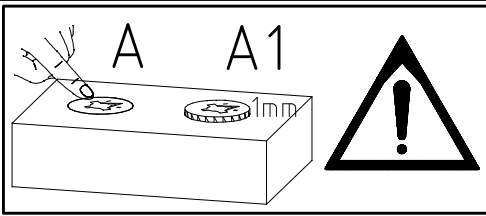

A1

3,5 x 15 mm



121 370

G1

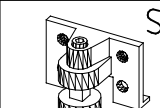

S0

111 300

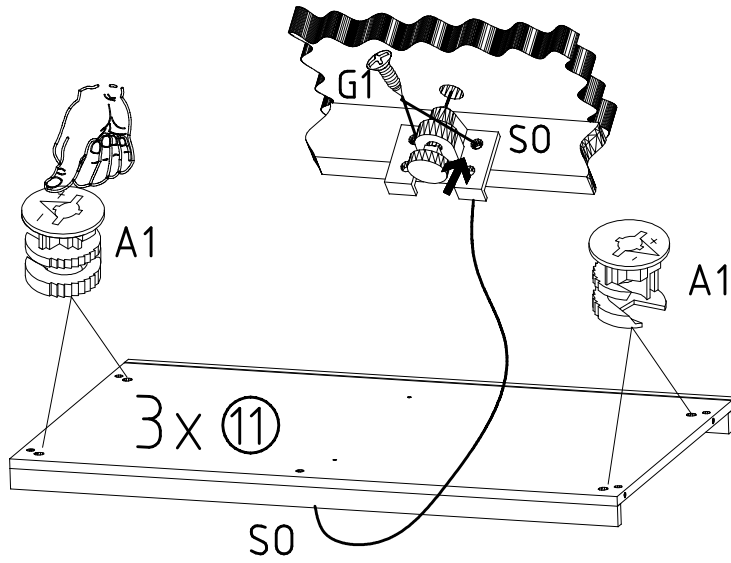

2



A1

111 149

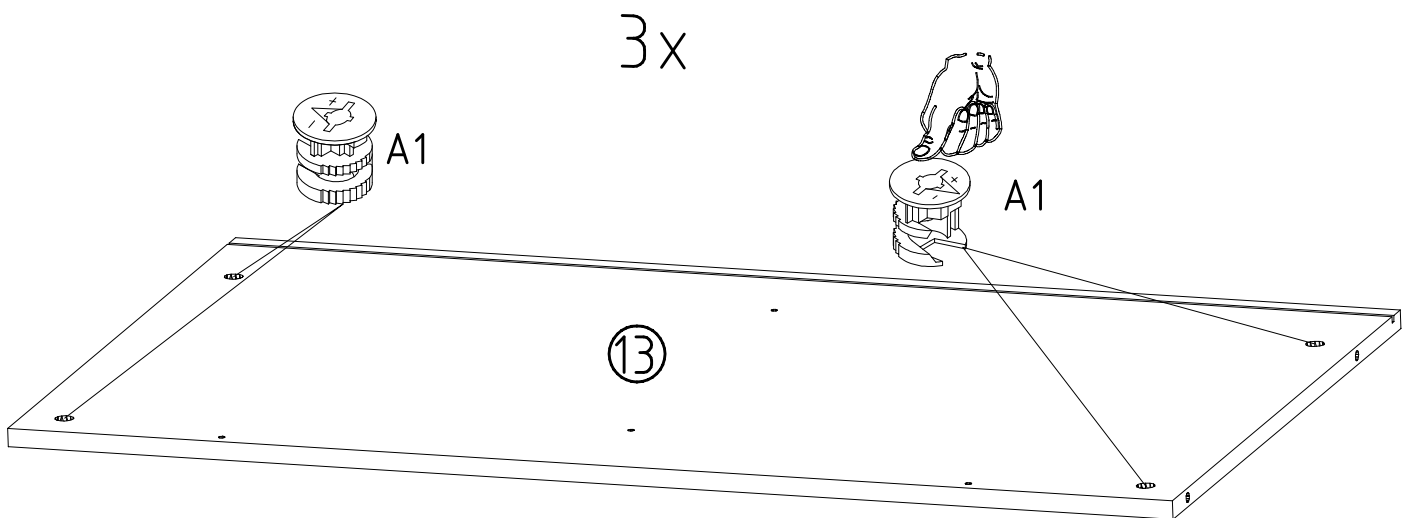

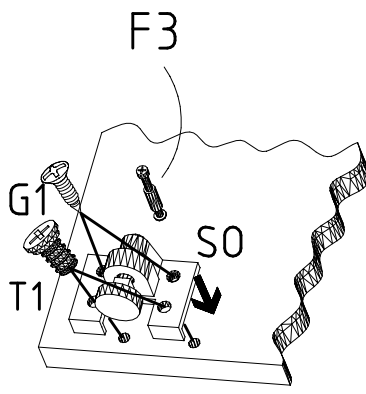
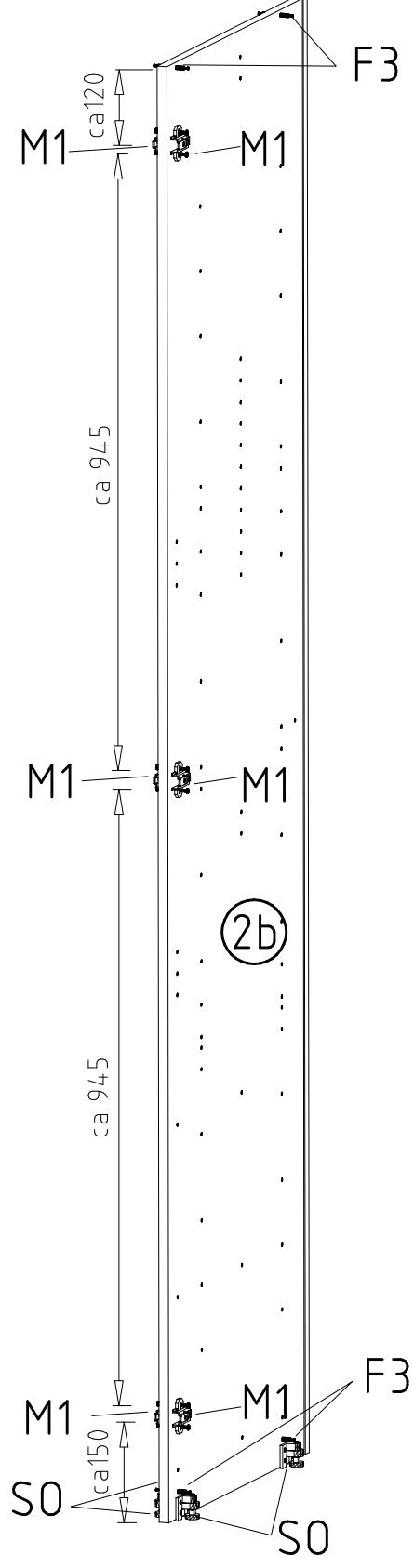
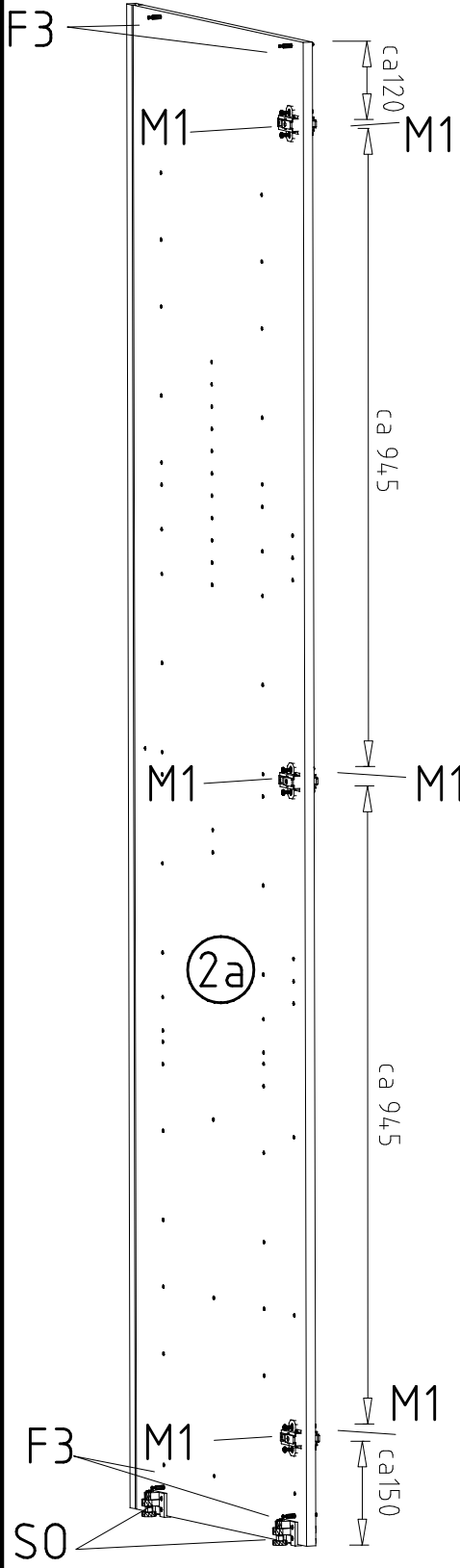
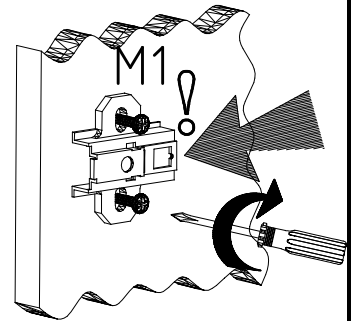
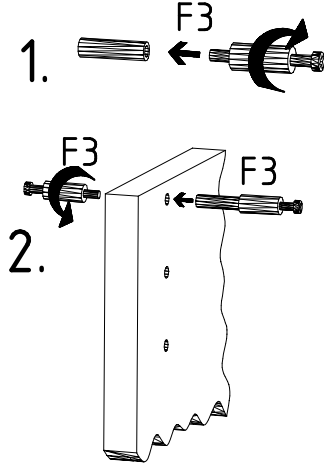
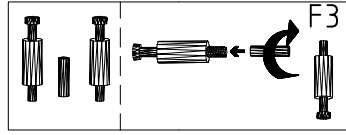

6,3 x 10,5 mm	T1
112 055	
3,5 x 15 mm	G1
121 370	
	M1
112 291	
	S0
111 300	
	F3

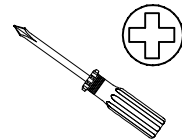

6,3 x 10,5 mm T1

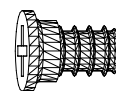

112 055

3,5 x 15 mm G1

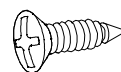

121 370

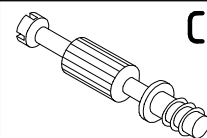

111 103

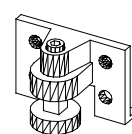

111 300

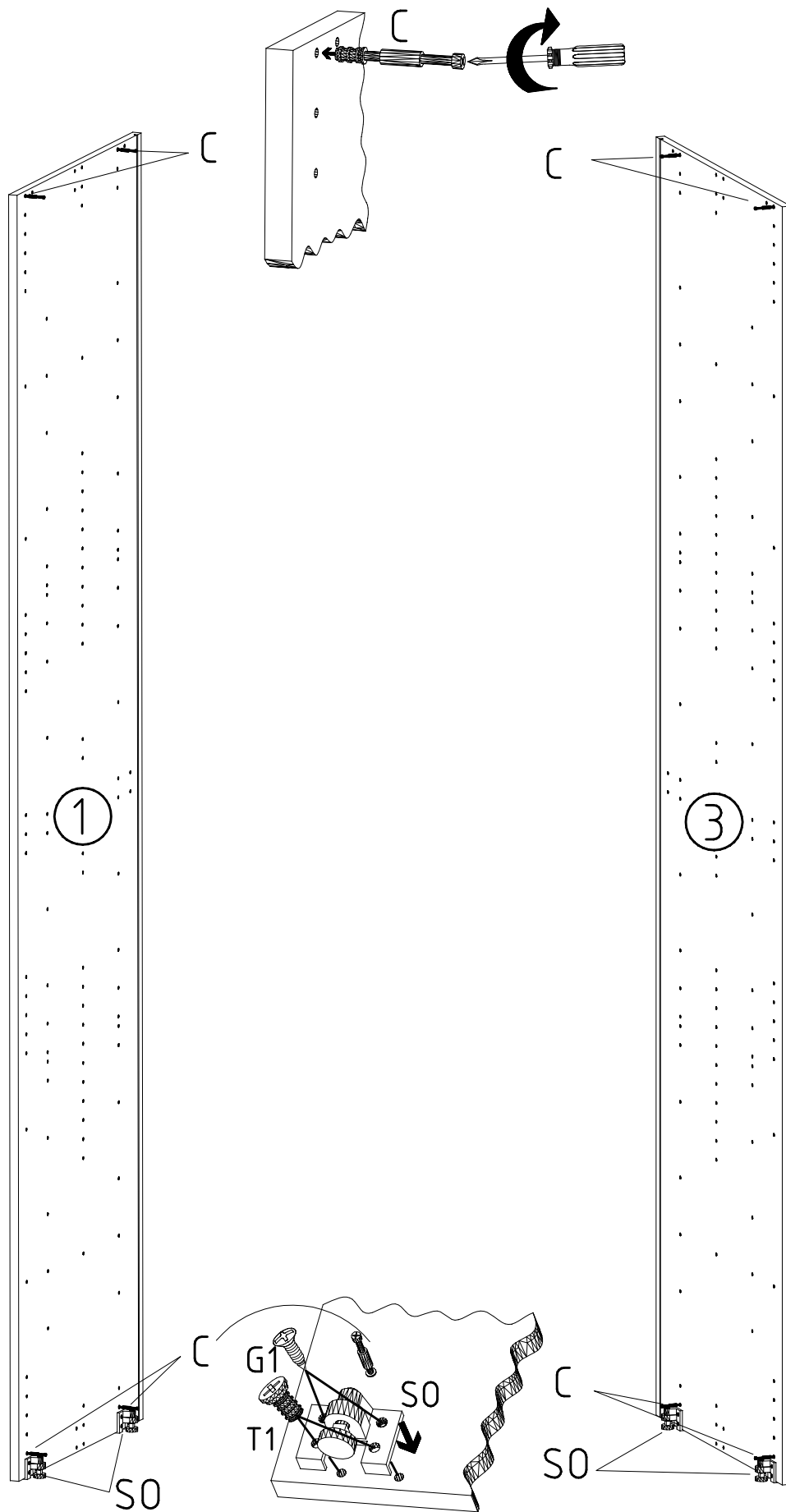

5

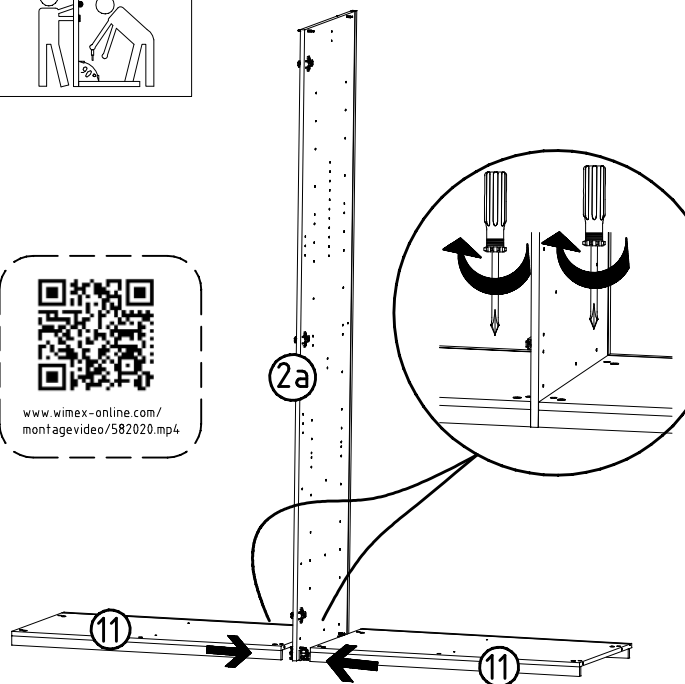
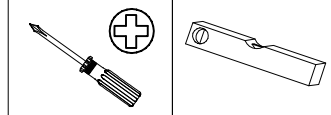

6

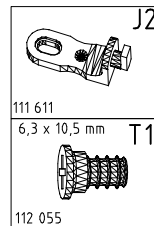
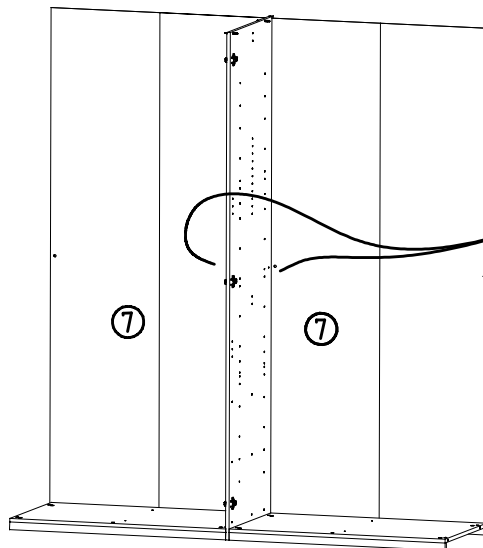
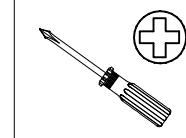

7

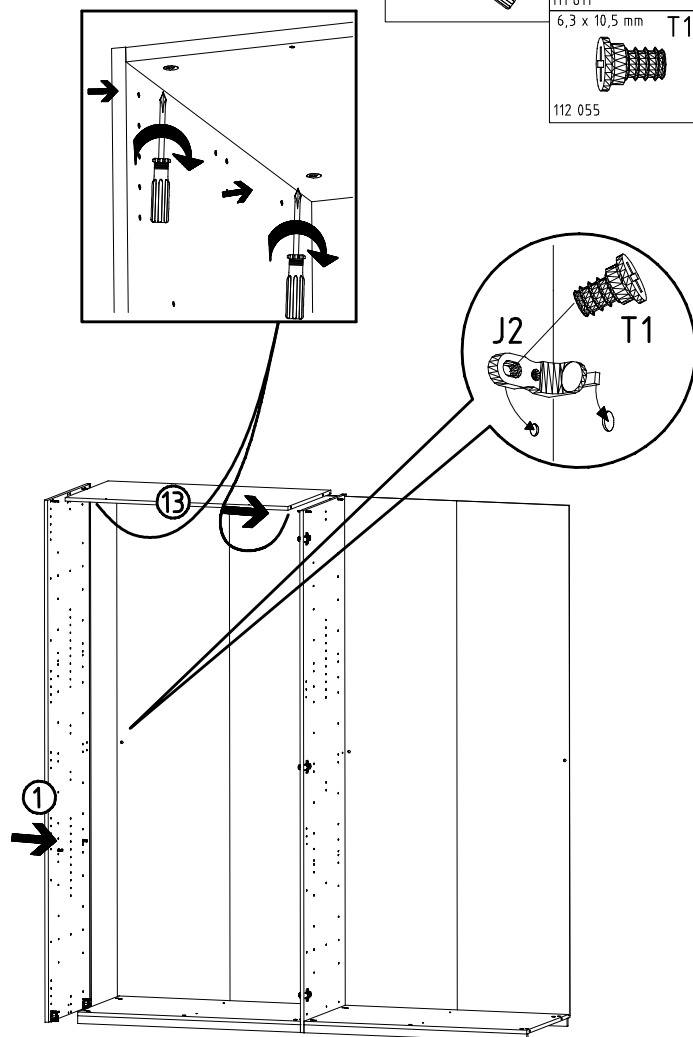
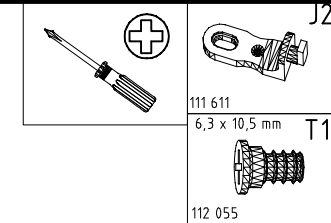

8

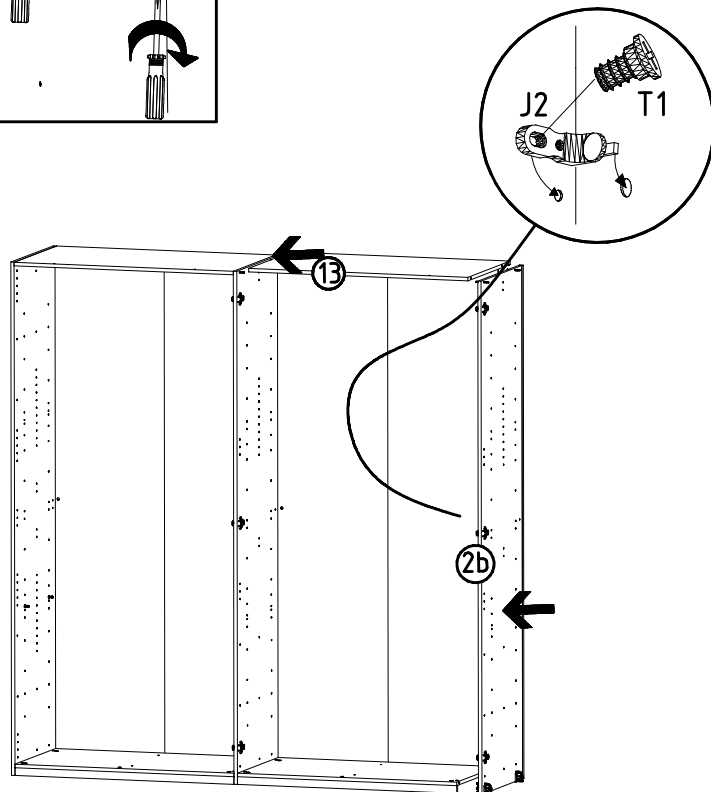
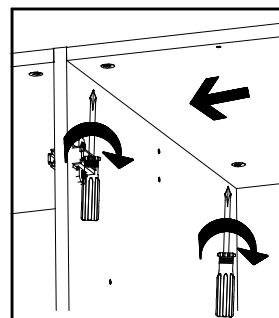
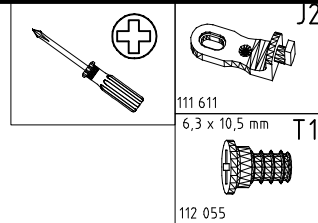

9

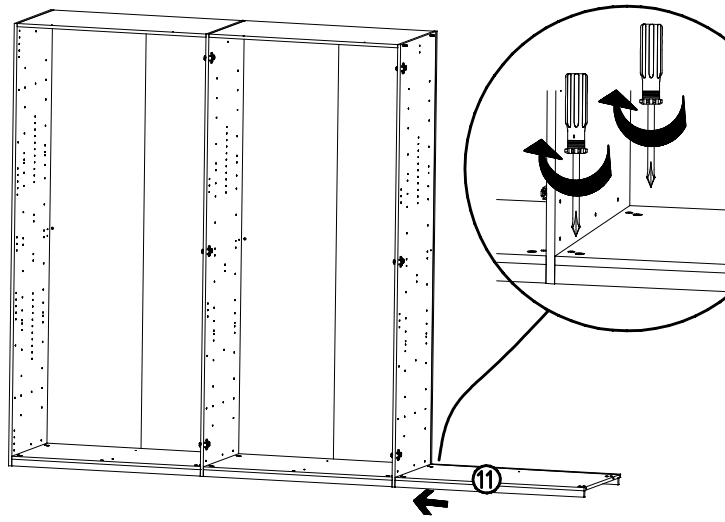
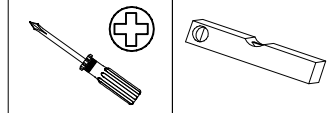
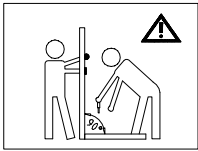

10

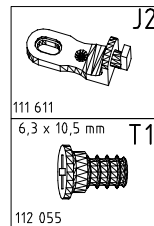
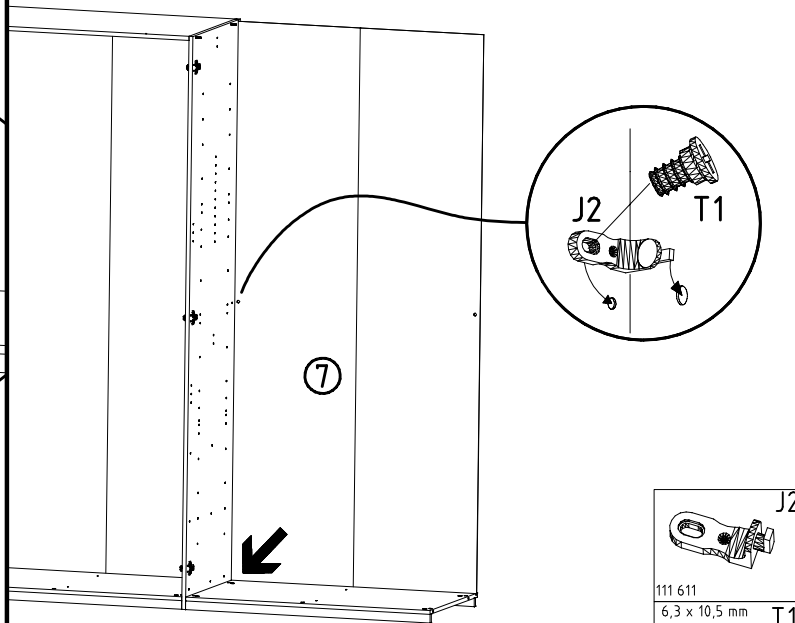
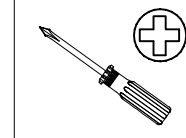

11

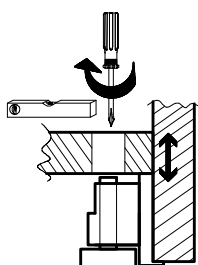
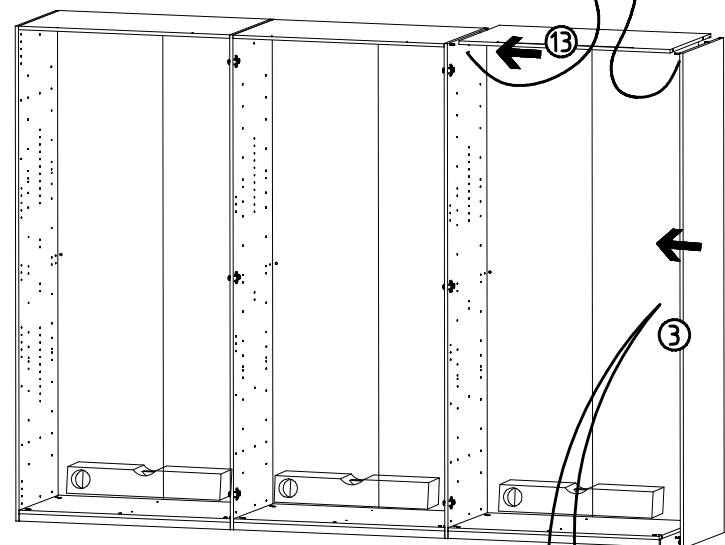
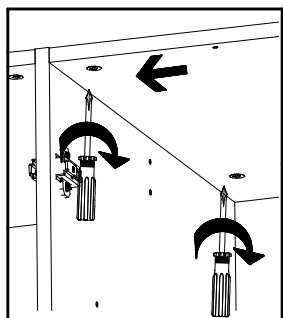
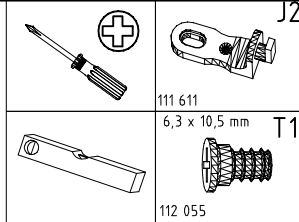

12

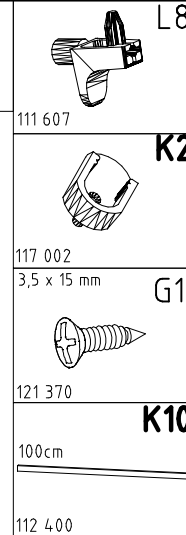
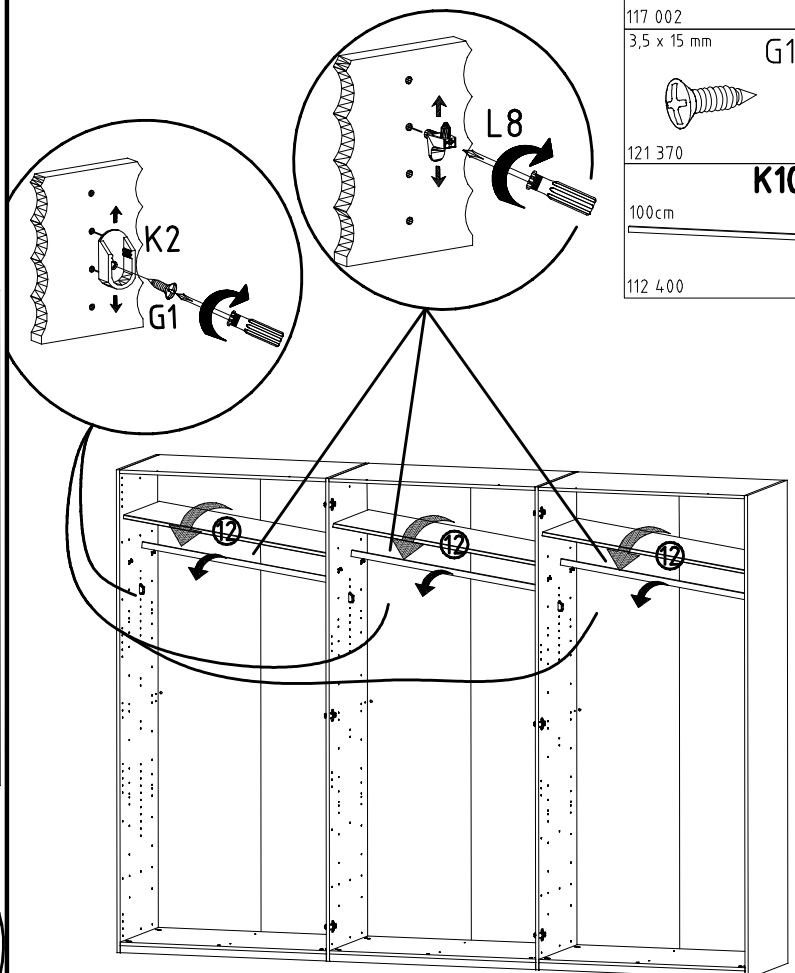
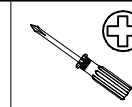

13

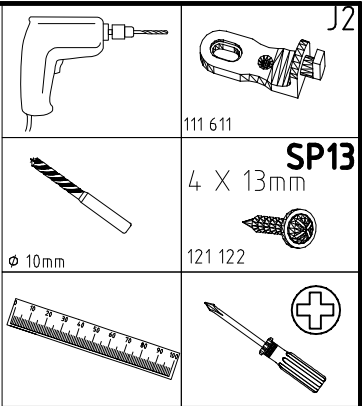
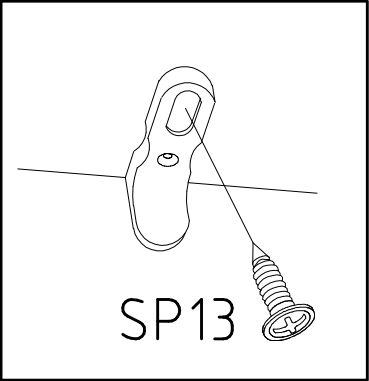
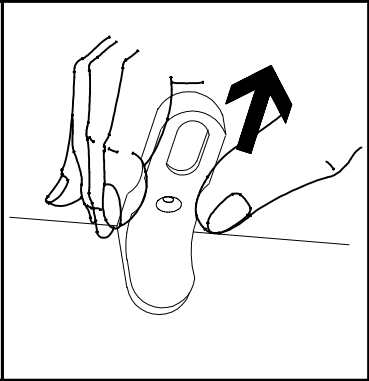
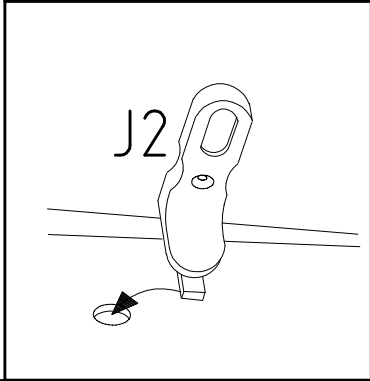
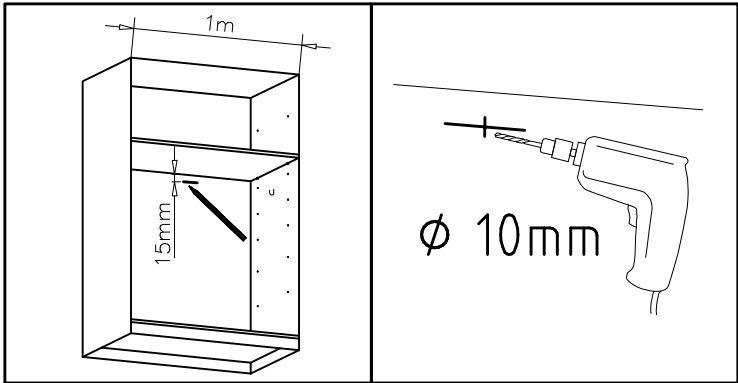
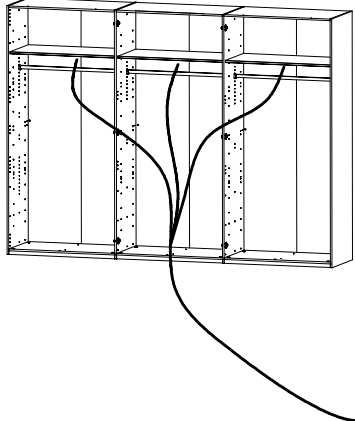

14

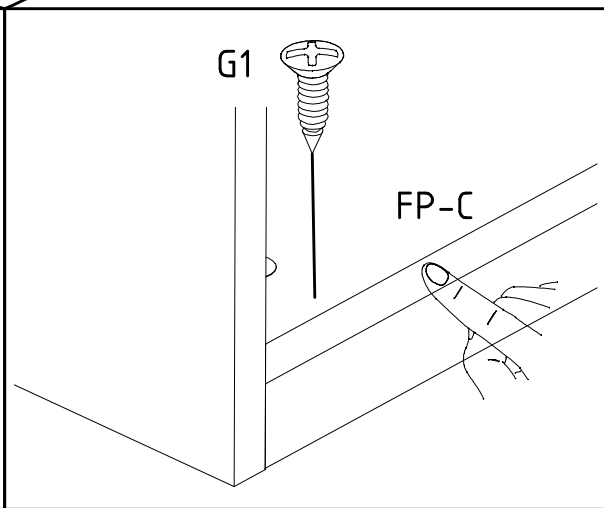
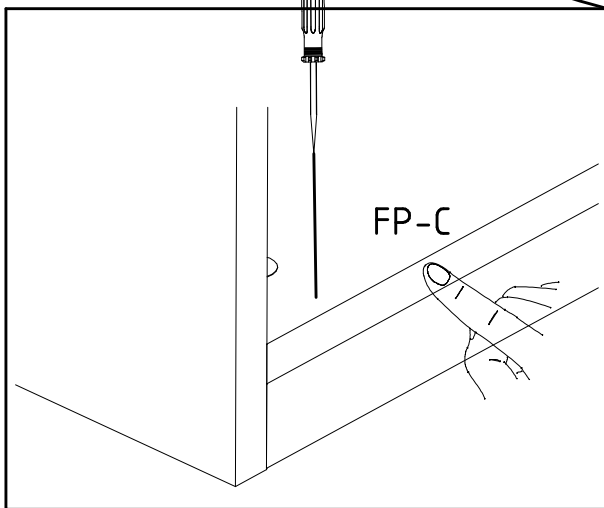
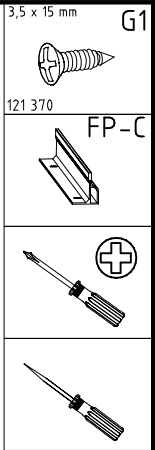
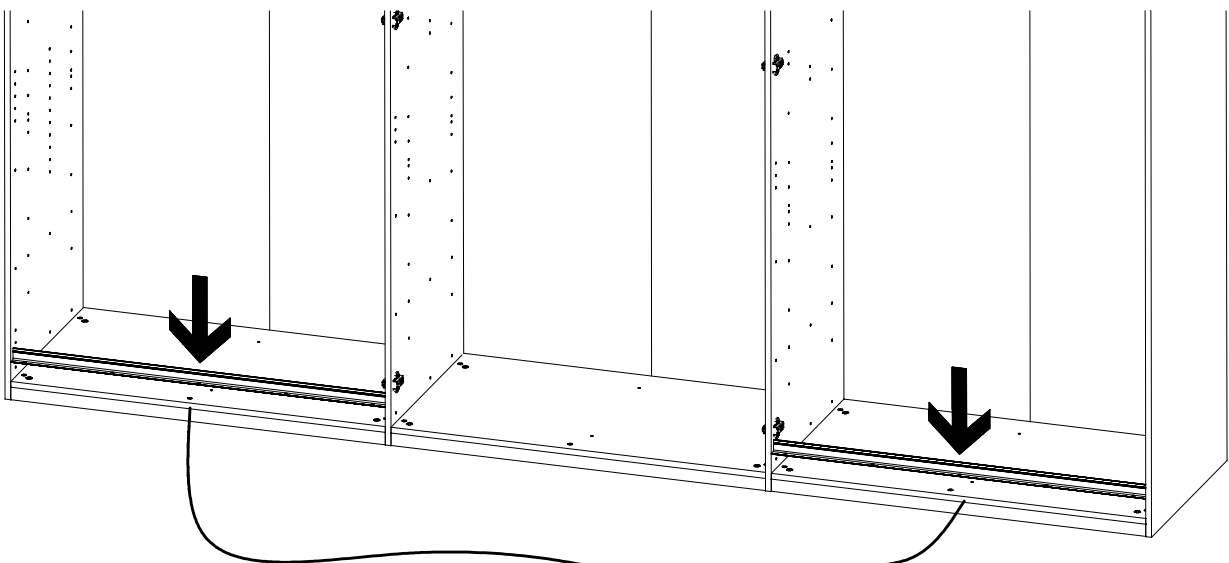



15

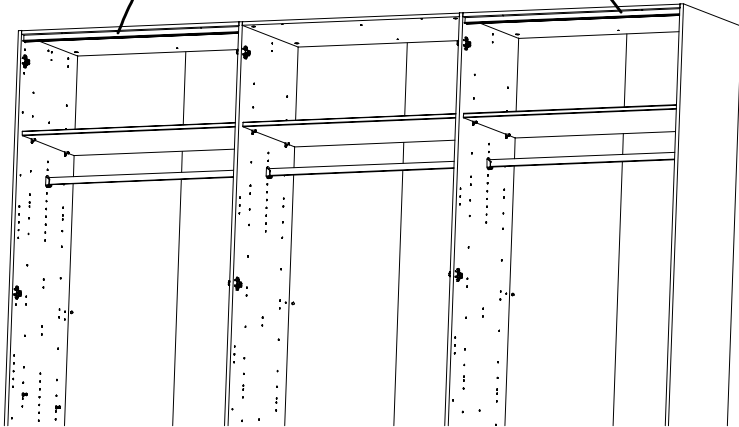
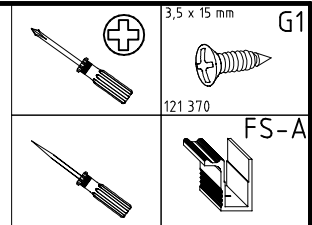
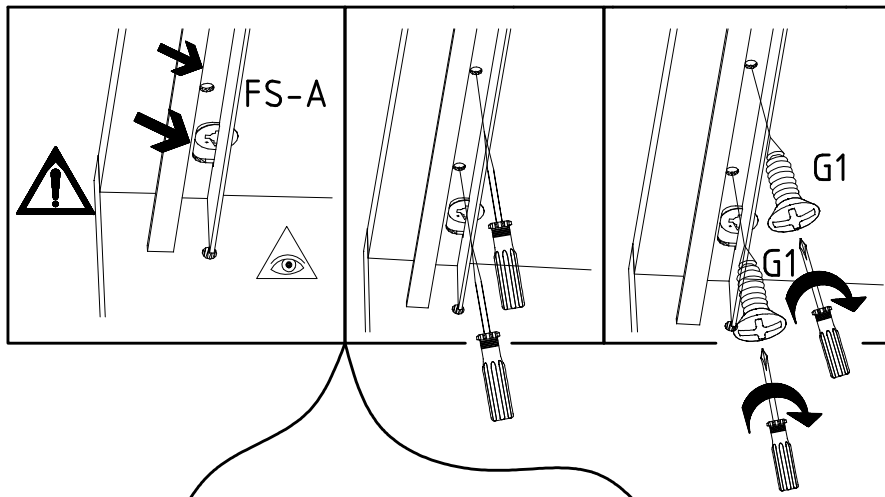

16

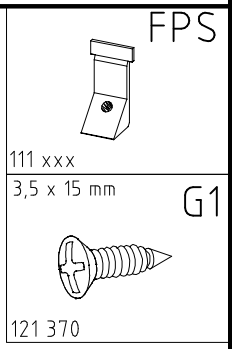
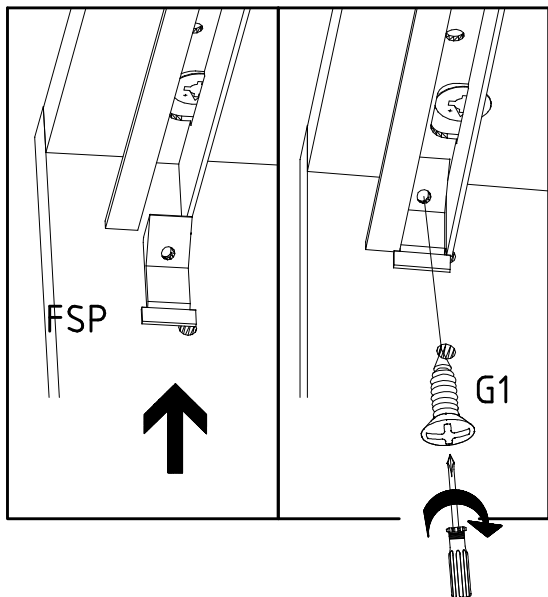
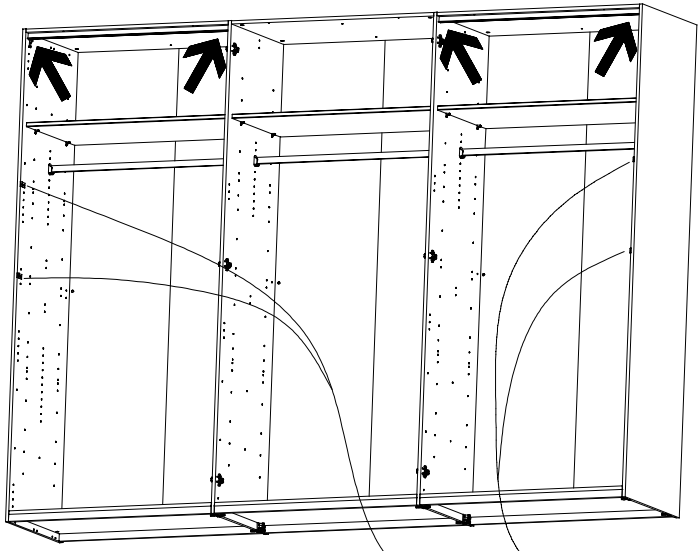

17

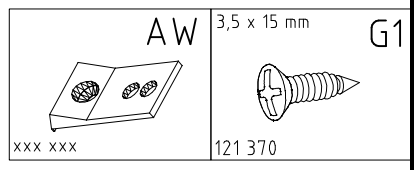
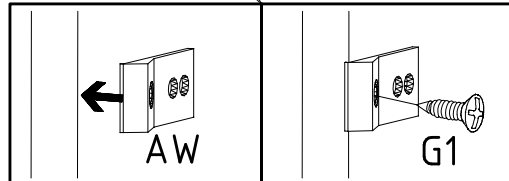

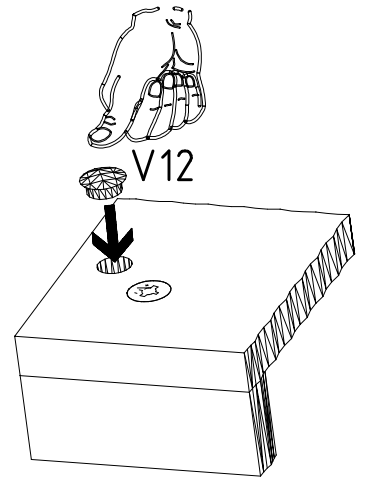
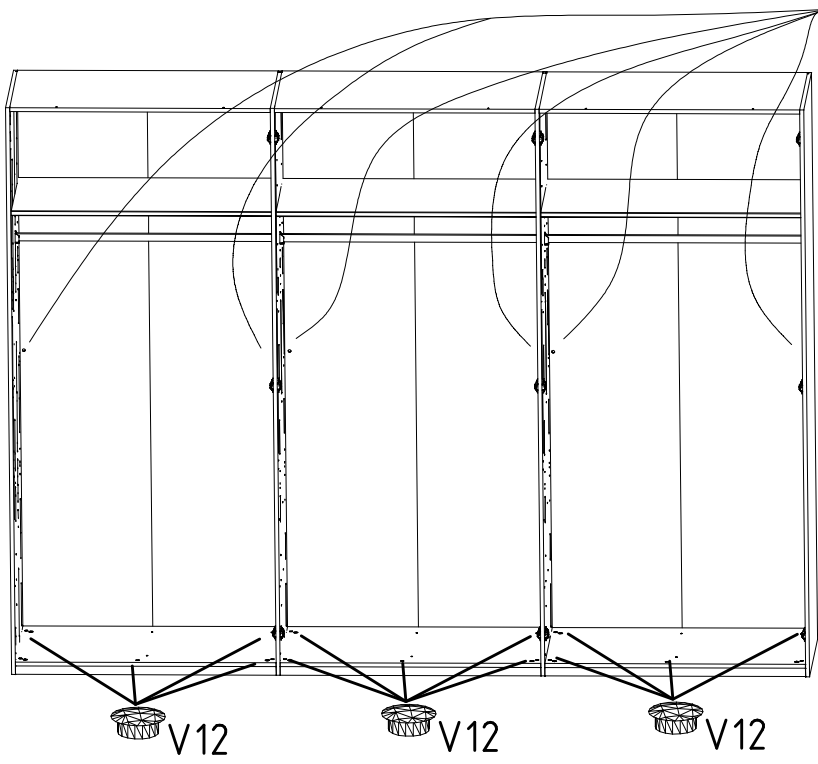
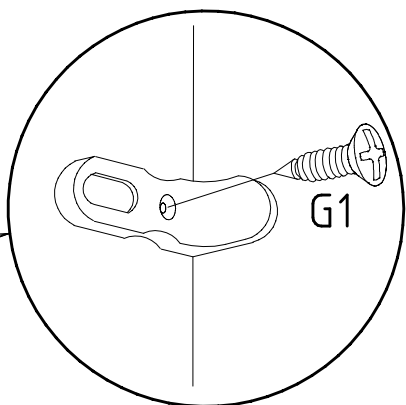
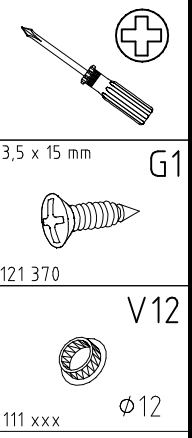
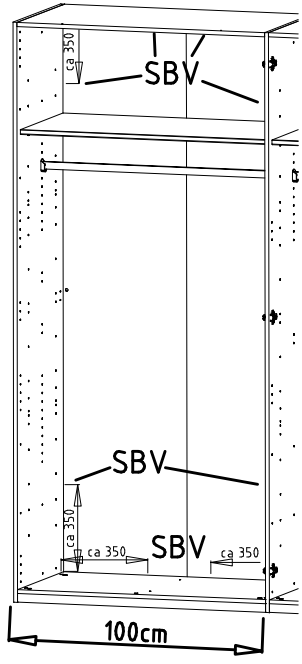
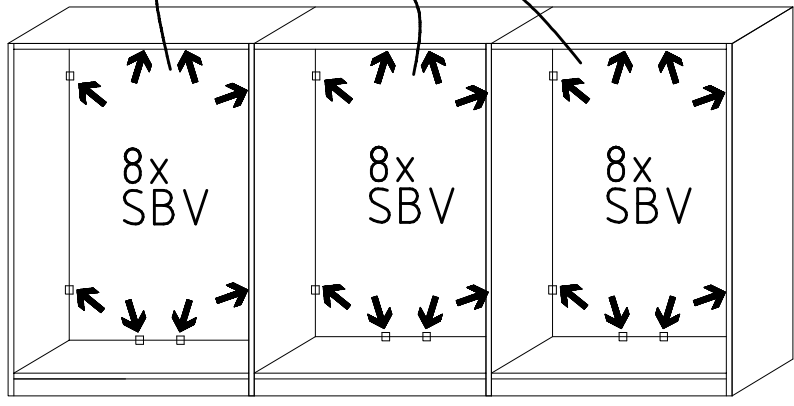
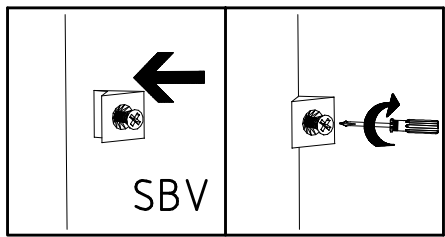
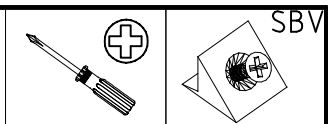

20

LRO-R

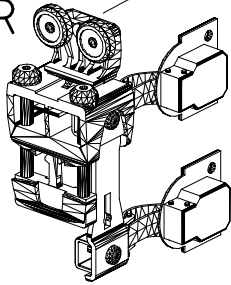

LRO-L

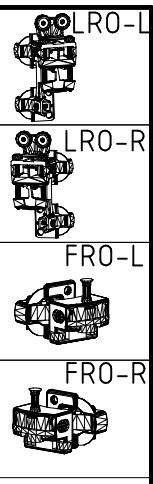
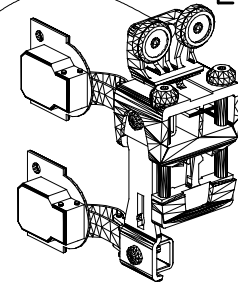

FRO-R

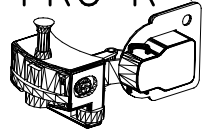

LRO-L/R

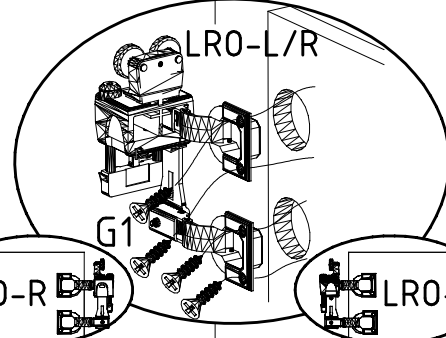

FRO-L

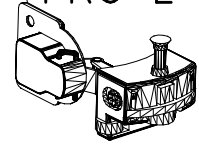

LRO-R

LRO-L

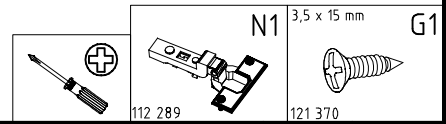
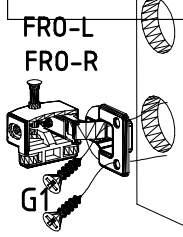
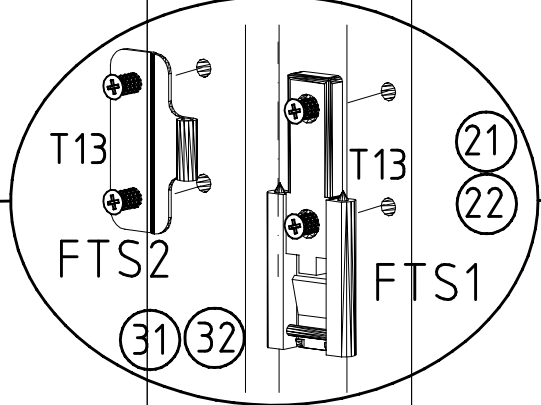
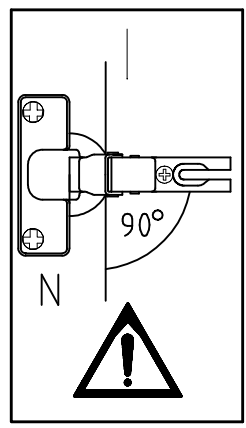
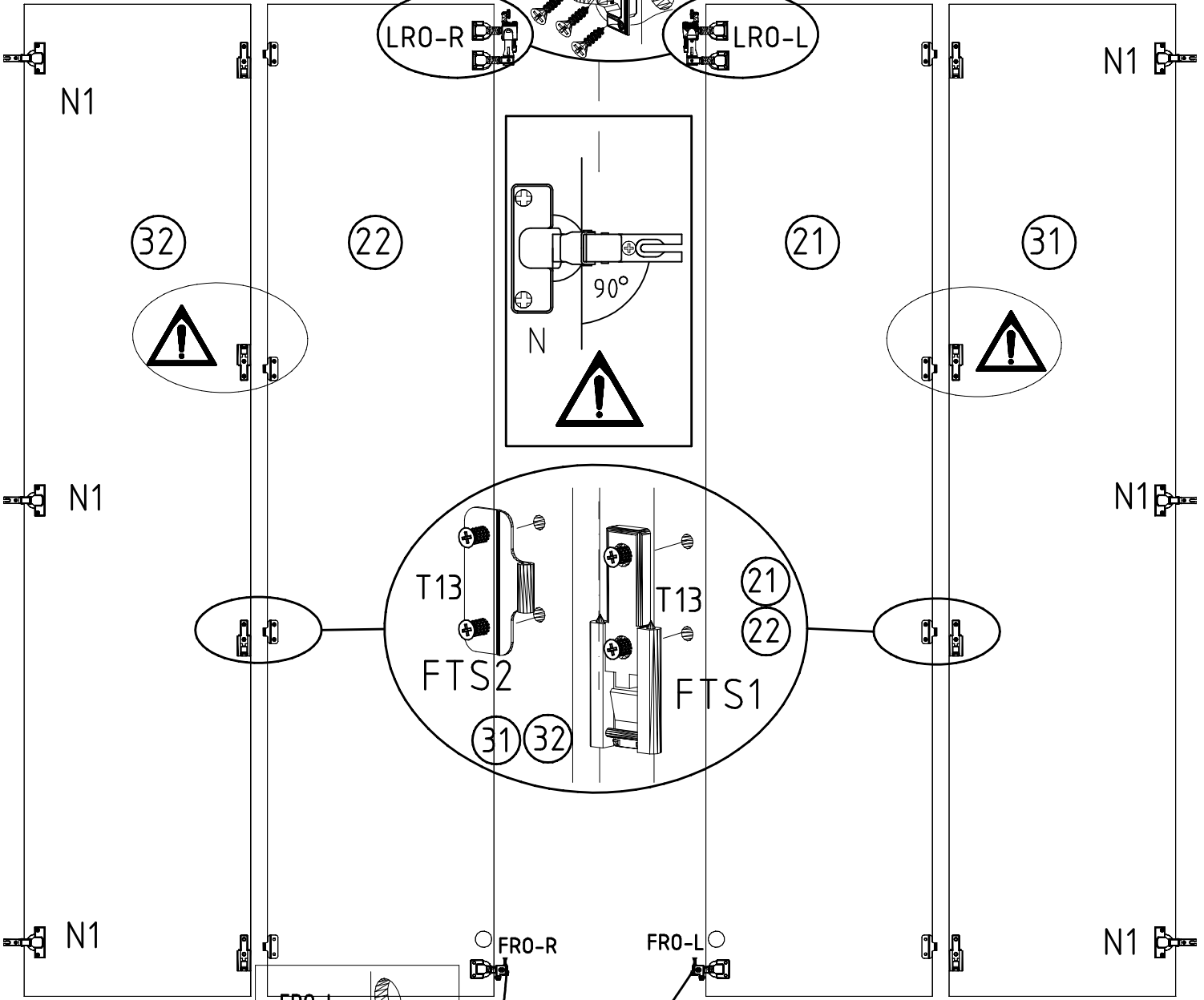

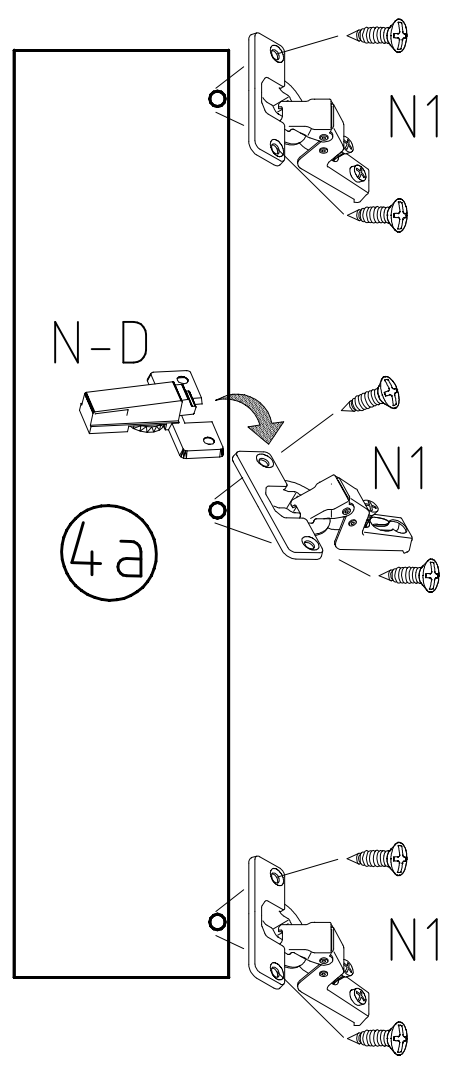
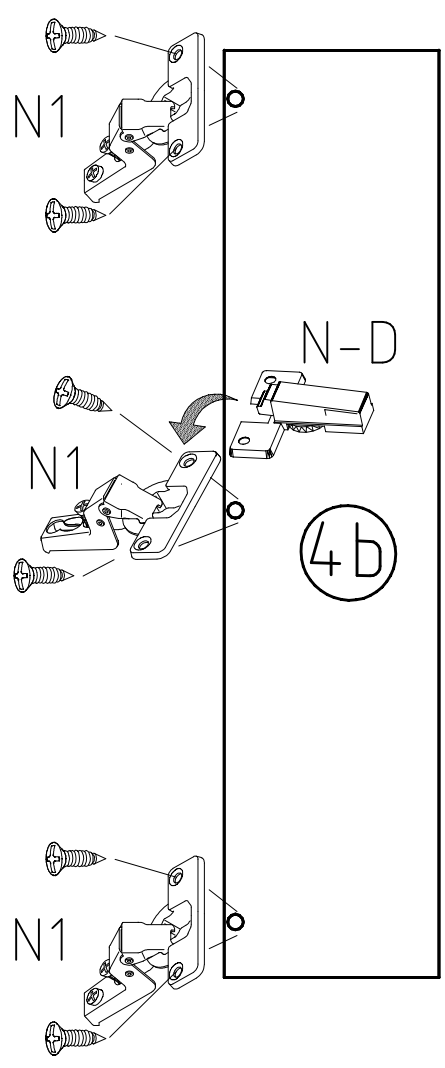

N1

112 289

N-D

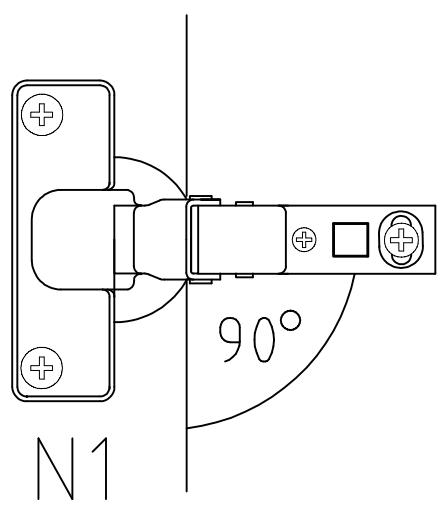

22

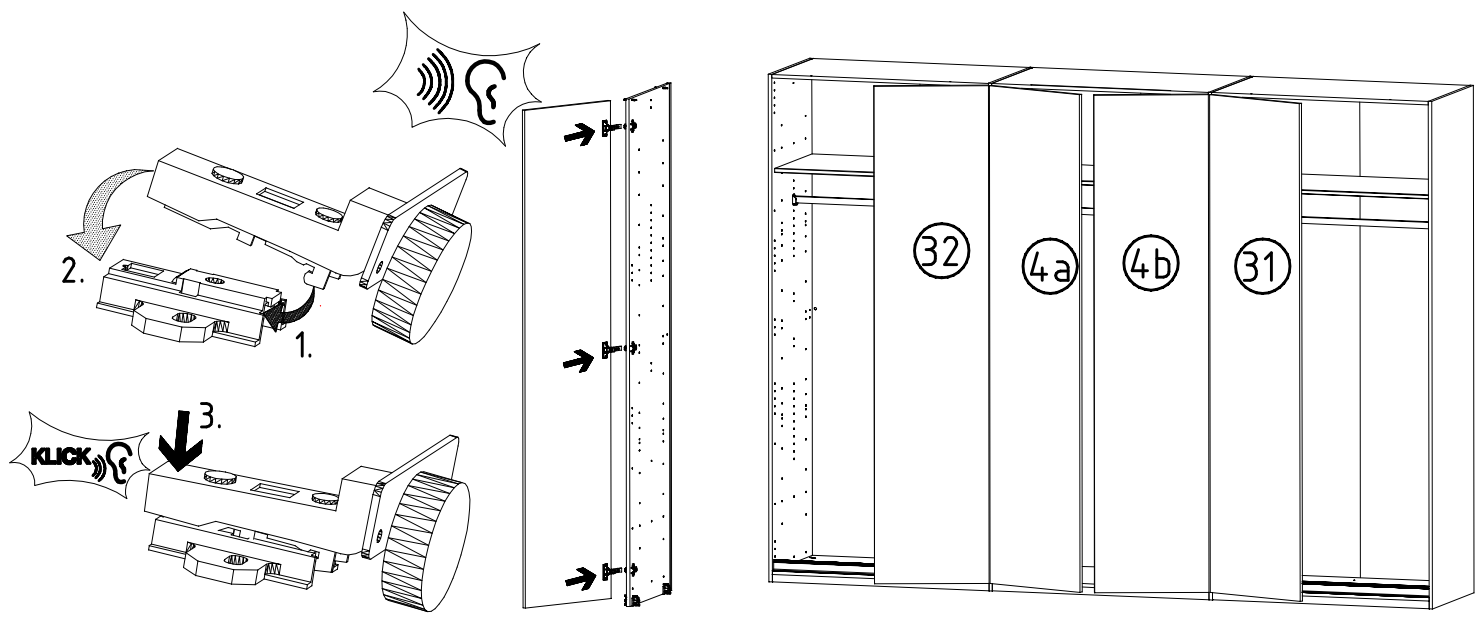

23

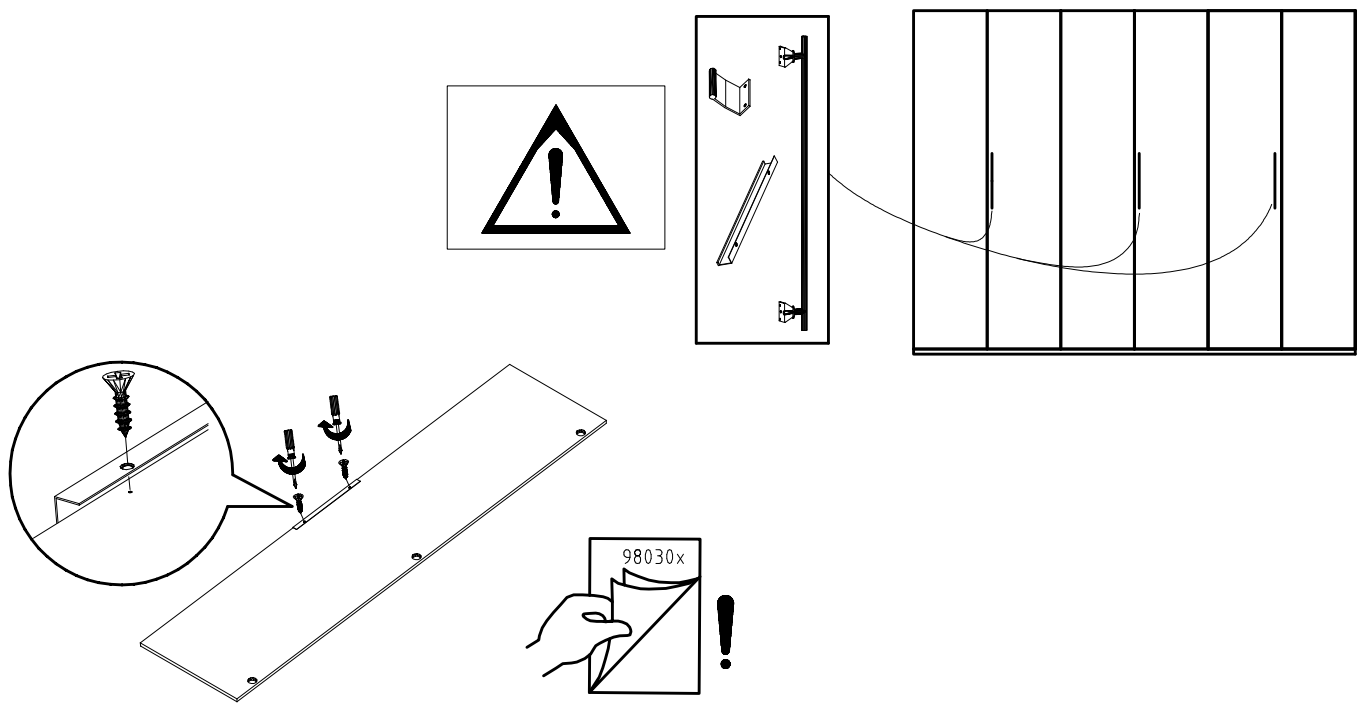

24

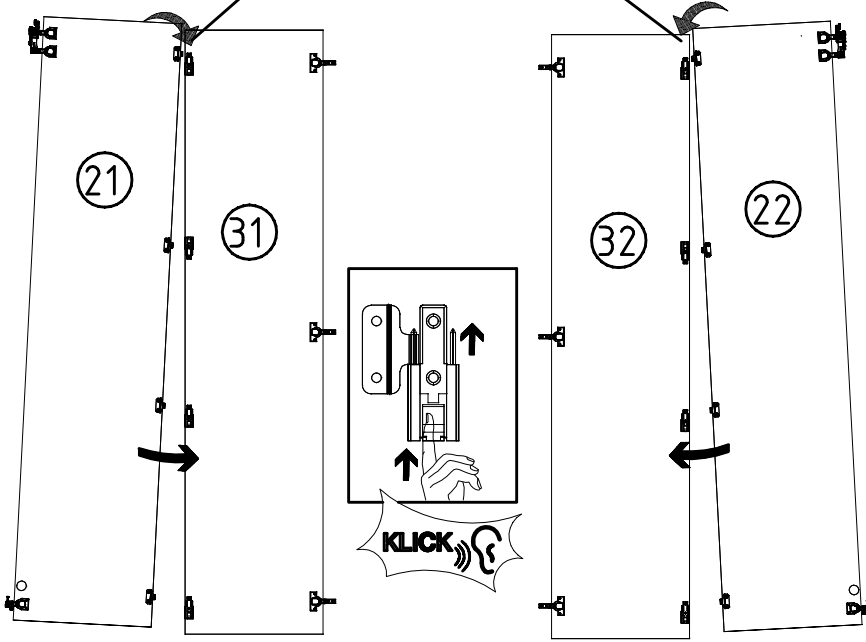
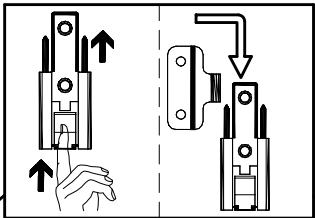
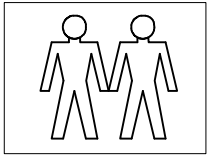
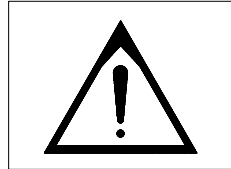

25

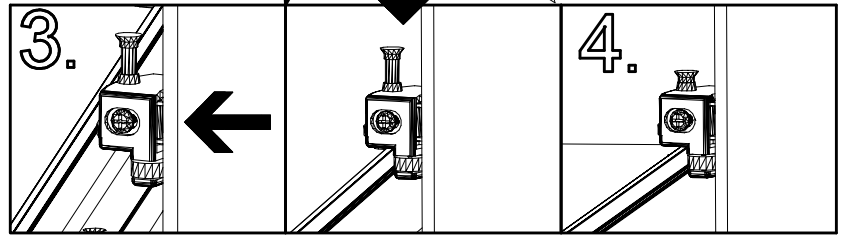
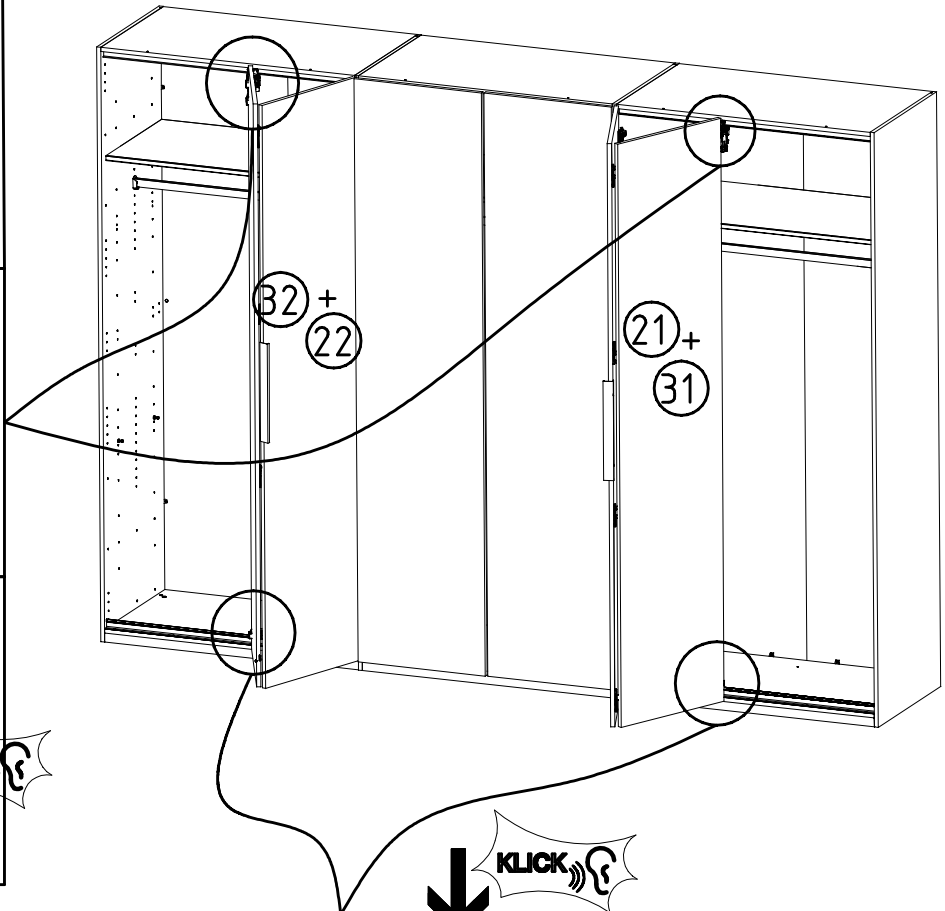
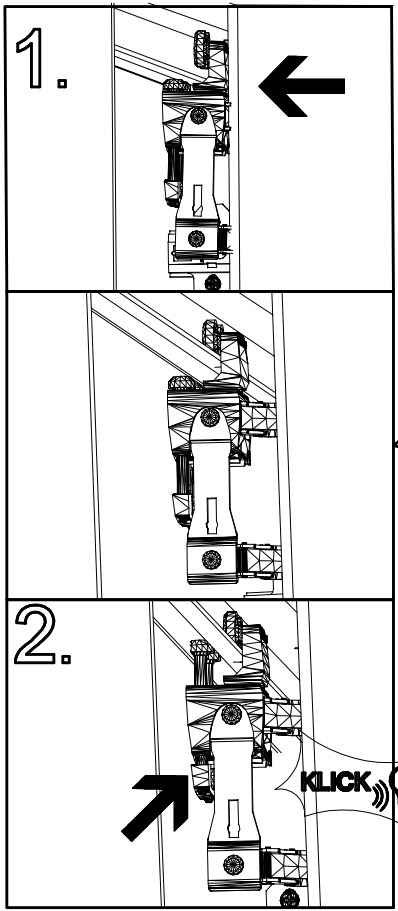

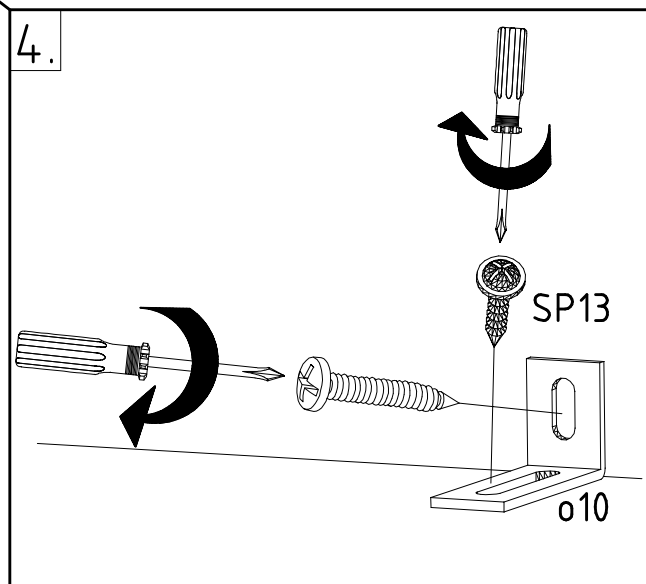
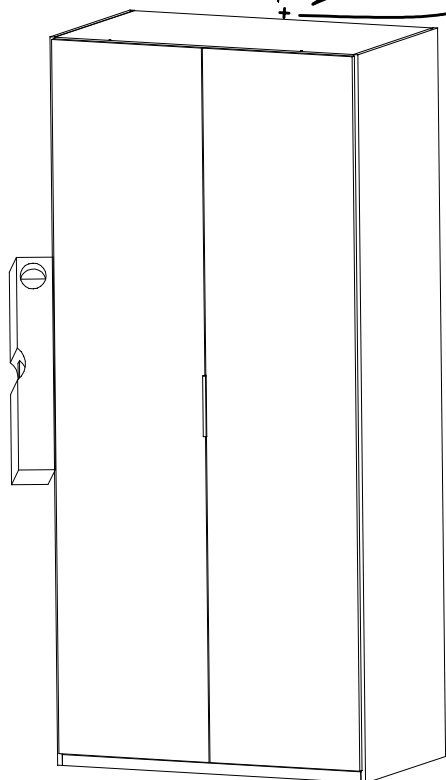
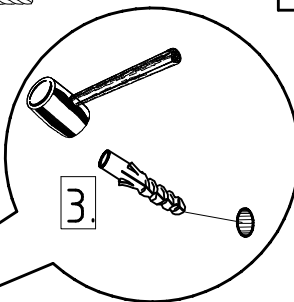
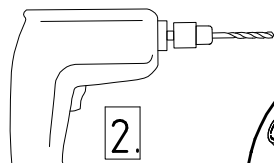
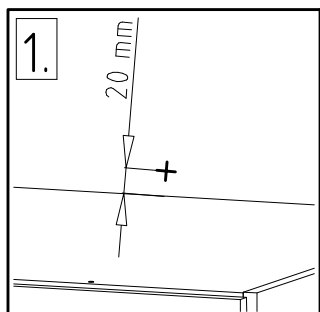
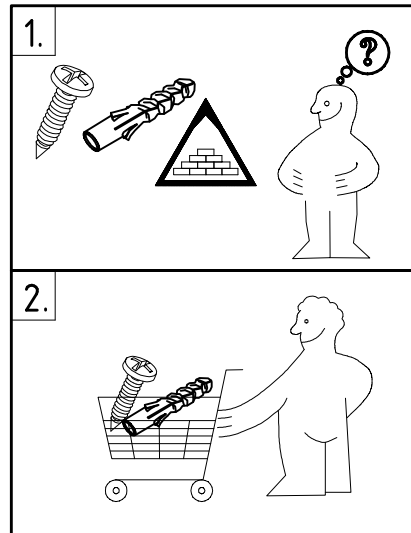
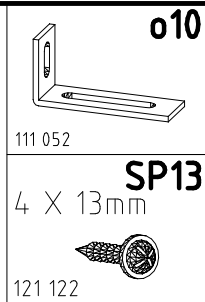
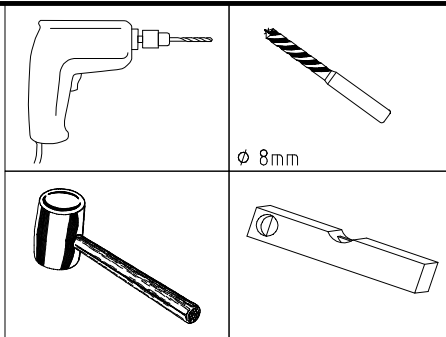

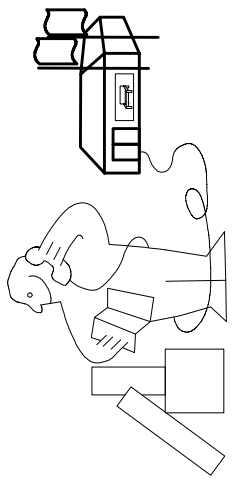
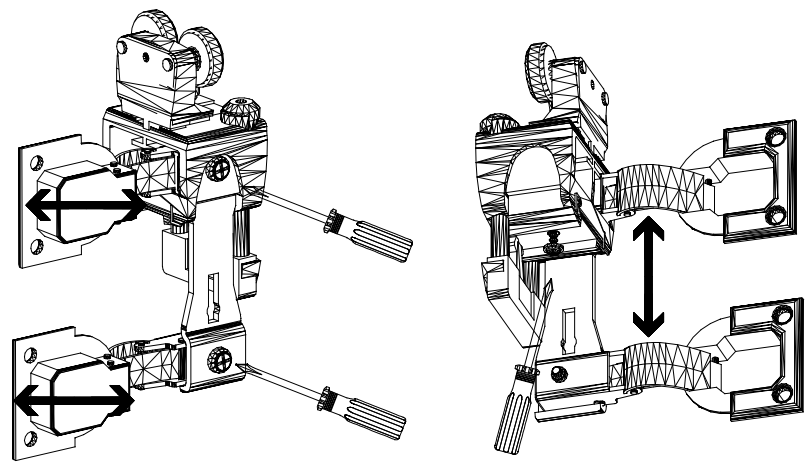
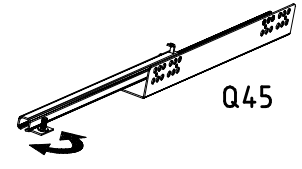
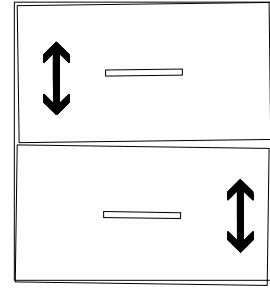
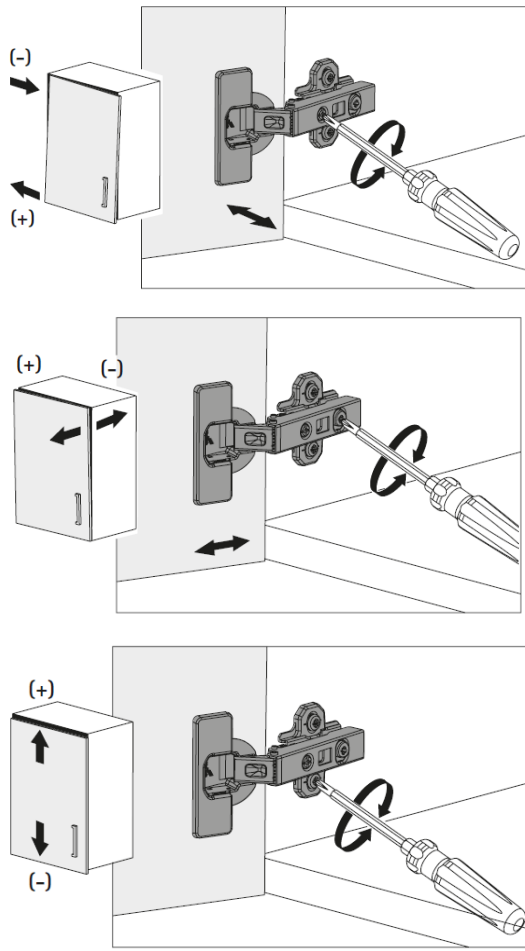

Modell/Model/Modèle

--	--	--	--	--	--

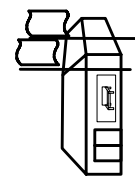
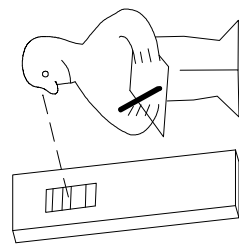

\_\_\_\_\_

\_\_\_\_\_

\_\_\_\_\_

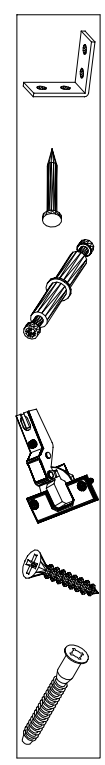

(121 370)	( G 1 )	(4x)

Änderungen die dem technischen Fortschritt geschuldet sind, behalten wir uns vor!  
 Bei nicht vorschriftsmäßiger und/ oder nicht fachmännischer Montage wird bei Personen- und/ oder Sachschäden keinerlei Haftung übernommen.